

4 Wheel 80V Electric Counterbalance Forklift

TECHNICAL SPECIFICATIONS

FHB25-35(L)-F2



TCM
Always Evolving

DIMENSIONS

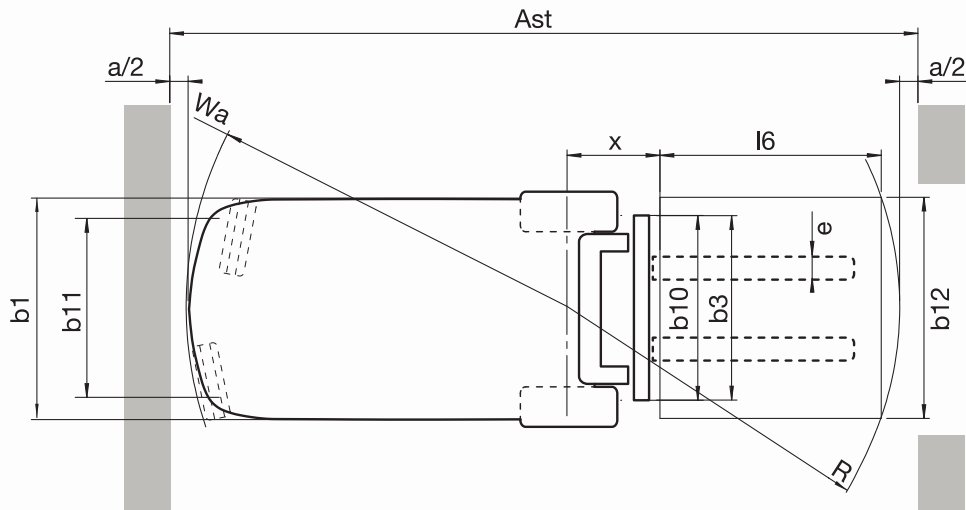
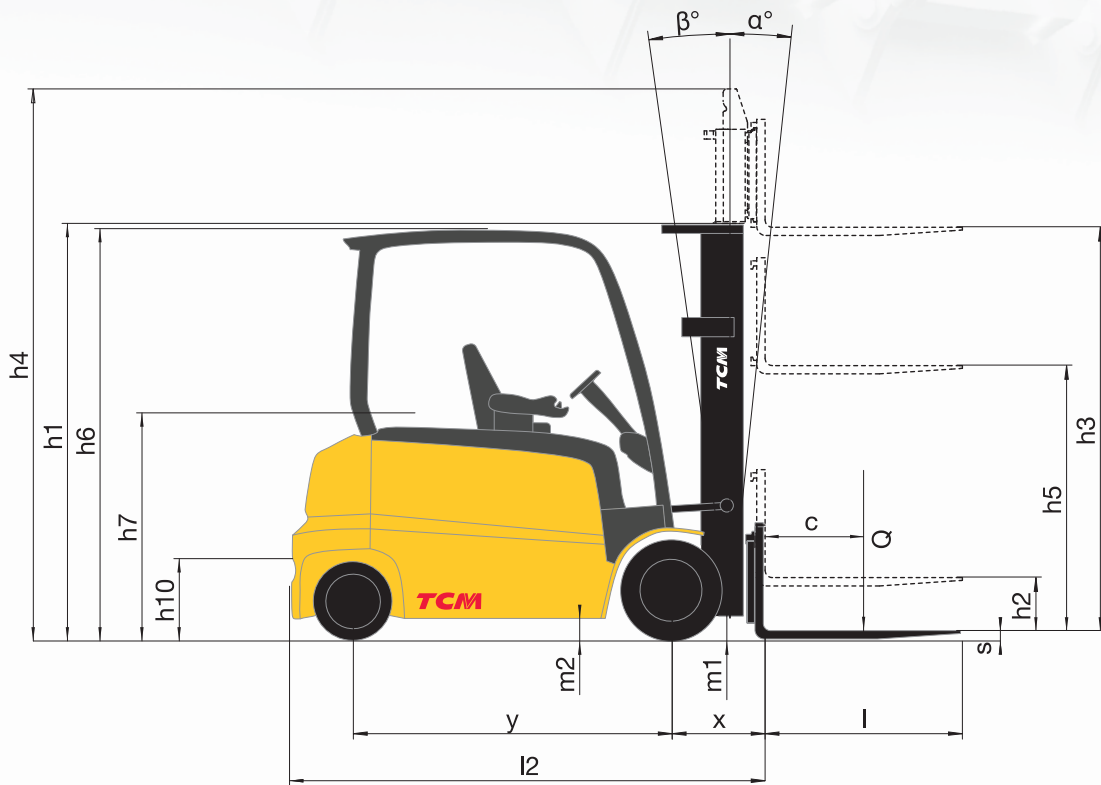

FHB25-35(L)-F2

STANDARD SPECIFICATIONS

CHARACTERISTICS							
1.1	Manufacturer	TCM Forklifts					
1.2	Manufacturer's model designation	FHB25-F2	FHB25L-F2	FHB30-F2	FHB30L-F2	FHB35L-F2	
1.3	Power source: (battery, diesel, LPG, petrol)	Electric	Electric	Electric	Electric	Electric	
1.4	Operator type: pedestrian, (operator) - standing, - seated	Seated	Seated	Seated	Seated	Seated	
1.5	Load capacity	Q (kg)	2500	2500	3000	3000	3500
1.6	Load centre distance	c (mm)	500	500	500	500	500
1.8	Load distance, axle to fork face	x (mm)	476	476	504	504	504
1.9	Wheelbase	y (mm)	1585	1730	1585	1730	1730
WEIGHT							
2.1	Truck weight, without load / including battery (simple x mast, lowest lift height)	kg	4584	4737	5222	5230	5654
2.2	Axle loading with maximum load, front / rear (simple x mast, lowest lift height)	kg	6296/788	6301/937	7351/870	7348/882	8183/971
2.3	Axle loading without load, front / rear (simple x mast, lowest lift height)	kg	2256/2328	2390/2347	2450/2771	2607/2623	2651/3002
WHEELS, DRIVE TRAIN							
3.1	Tyres: V = solid, L = pneumatic, SE = solid pneumatic - front / rear		SE	SE	SE	SE	SE
3.2	Tyre dimensions, front		23 x 9 - 10	23 x 9 - 10	23 x 10 - 12	23 x 10 - 12	23 x 10 - 12
3.3	Tyre dimensions, rear		18 x 7 - 8	18 x 7 - 8	18 x 7 - 8	18 x 7 - 8	18 x 7 - 8
3.5	Number of wheels, front / rear (x = driven)		2 x / 2	2 x / 2	2 x / 2	2 x / 2	2 x / 2
3.6	Track width (centre of tyres), front	b10 (mm)	985	985	950	950	950
3.7	Track width (centre of tyres), rear	b11 (mm)	970	970	970	970	970
DIMENSIONS							
4.1	Mast tilt, forwards / backwards	∅ / β °	6 / 8	6 / 8	6 / 8	6 / 8	6 / 8
4.2	Height with mast lowered (see tables)	h1 (mm)	2145	2145	2165	2165	2291
4.3	Free lift (see tables)	h2 (mm)	100	100	100	100	100
4.4	Lift height (see tables)	h3 (mm)	3300	3300	3270	3270	3300
4.5	Overall height with mast raised	h4 (mm)	4355	4355	4325	4325	4345
4.7	Height to top of overhead guard	h6 (mm)	2240	2240	2240	2240	2240
4.8	Seat height	h7 (mm)	1130	1130	1130	1130	1130
4.12	Tow coupling height	h10 (mm)	395	395	395	395	395
4.19	Overall length	l1 (mm)	3459	3600	3487	3628	3628
4.2	Length to fork face (includes fork thickness)	l2 (mm)	2389	2530	2417	2558	2558
4.21	Overall width	b1 / b2 (mm)	1190	1190	1190	1190	1190
4.22	Fork dimensions (thickness, width, length)	s / e / l (mm)	40 x 100 x 1100	40 x 100 x 1100	45 x 125 x 1100	45 x 125 x 1100	45 x 125 x 1100
4.23	Fork carriage to DIN 15 173 A / B / no		2A	2A	3A	3A	3A
4.24	Fork carriage width	b3 (mm)	1000	1000	1000	1000	1000
4.31	Ground clearance under mast, with load	m1 (mm)	105	105	115	115	115
4.32	Ground clearance at centre of wheelbase, with load (forks lowered)	m2 (mm)	122	122	122	122	122
4.33	Working aisle width with 1000 x 1200 mm pallets, crosswise	Ast (mm)	3660	3805	3690	3830	3830
4.34a	Working aisle width with 800 x 1200 mm pallets, crosswise	Ast (mm)	3605	3749	3629	3773	3773
4.34b	Working aisle width with 800 x 1200 mm pallets, lengthwise	Ast (mm)	3815	3960	3840	3985	3985
4.35	Turning circle radius	Wa (mm)	1920	2064	1920	2064	2064
4.36	Minimum distance between centres of rotation	b13 (mm)	160	160	160	160	160
PERFORMANCE							
5.1	Travel speed, with / without load	km / h	20 / 20	20 / 20	20 / 20	20 / 20	18 / 18
5.2	Lifting speed, with / without load	m / s	0.5 / 0.65	0.5 / 0.65	0.45 / 0.6	0.45 / 0.6	0.45 / 0.6
5.3	Lowering speed, with / without load	m / s	0.55 / 0.5	0.55 / 0.5	0.5 / 0.45	0.5 / 0.45	0.5 / 0.45
5.5	Rated drawbar pull, with / without load	N	9300 / 9700	9300 / 9700	9100 / 9550	9100 / 9550	8950 / 9500
5.6	Maximum drawbar pull, with / without load (5 min short duty)	N	15800 / 16200	15800 / 16200	15550 / 16050	15550 / 16050	15400 / 16000
5.7	Gradeability, with / without load	%	15 / 25	15 / 25	13 / 22	13 / 22	12 / 20
5.8	Maximum gradeability with / without load	%	23 / 38	23 / 38	20 / 33	20 / 34	18 / 31
5.9	Acceleration time (10 metres) with / without load	s	4.1 / 3.8	4.1 / 3.8	4.2 / 3.8	4.2 / 3.8	4.4 / 3.8
5.1	Service brakes (mechanical / hydraulic / electric / pneumatic)		Hydraulic	Hydraulic	Hydraulic	Hydraulic	Hydraulic
ELECTRIC MOTOR							
6.1	Drive motor capacity (60 min. short duty)	kW	2 x 8	2 x 8	2 x 8	2 x 8	2 x 8
6.2	Lift motor output at 15% duty factor	kW	20.8	20.8	25.5	25.5	25.5
6.3	Dattery to DIN 43 531 / 35 / 36 A / B / C / no		43536A	43536A	43536A	43536A	43536A
6.4	Battery voltage / capacity at 5 - hour discharge	V / Ah	80 / 560 - 620	80 / 700 - 775	80 / 560 - 620	80 / 700 - 775	80 / 700 - 775
6.5	Battery weight	kg	1558	1863	1558	1863	1863
MISCELLANEOUS							
8.1	Type of drive control		AC	AC	AC	AC	AC
10.1	Maximum operating pressure for attachments	bar	185	185	185	185	205**
10.2	Oil flow for attachments	l / min	30	30	30	30	30
10.7	Noise level, value at operator's ear (EN 12053)	dB (A)	65	65	66	66	66
10.8	Towing coupling, type DIN 15170		DIN 15170 - H	DIN 15170 - H	DIN 15170 - H	DIN 15170 - H	DIN 15170 - H

1) 30/45/60 cycle per hour test (whichever applies for that product)

MAST SPECIFICATIONS & RATED CAPACITIES

MAST TYPE	Max fork height (mm)	Overall mast height (mm)		Free lift (mm)	Mast tilt forward / backward (degrees)	FHB25-F2		FHB25L-F2	
		Lowered	Extended			Load Capacity (kgs) @ load centre (mm)		Load Capacity (kgs) @ load centre (mm)	
						500	600	500	600
2 STAGE	3000	1995*	4055	100	6 - 8	2500	2250	2500	2250
	3300	2145*	4355	100	6 - 8	2500	2250	2500	2250
	3740	2410	4795	100	6 - 8	2500	2250	2500	2250
	4100	2590	5155	100	6 - 8	2500	2250	2500	2250
	4500	2800	5555	100	6 - 8	2500	2250	2500	2250
	5000	3050	6055	100	6 - 8	2475	2250	2500	2250
	5500	3300	6555	100	6 - 4	2400	2225	2450	2250
	6000	3550	7055	100	6 - 4	2000	2000	2000	2000
2 STAGE FULL FREE LIFT	3000	1995*	4055	940	6 - 8	2500	2250	2500	2250
	3300	2145*	4355	1090	6 - 8	2500	2250	2500	2250
	3700	2410	4755	1355	6 - 8	2500	2250	2500	2250
3 STAGE FULL FREE LIFT	4020	2590	5075	1535	6 - 8	2500	2250	2500	2250
	3730	1805*	4785	750	6 - 6	2500	2250	2500	2250
	4030	1905*	5085	850	6 - 6	2500	2250	2500	2250
	4300	1995*	5355	940	6 - 6	2500	2250	2500	2250
	4750	2145*	5805	1090	6 - 6	2500	2250	2500	2250
	5060	2265	6115	1210	6 - 6	2450	2250	2500	2250
	5500	2410	6555	1355	6 - 4	2350	2200	2500	2250
	5990	2590	7045	1535	6 - 4	2275	2075	2375	2225
	6500	2850	7555	1795	6 - 4	2075	2025	1925	1925
	7000	3050	8055	1995	6 - 4	1575	1575	1475	1475

* Lower than overheadguard

** Without standard backrest: Extended height -395mm. Free lift height +395mm (full free lift masts only)

MAST TYPE	Max fork height (mm)	Overall mast height (mm)		Free lift (mm)	Mast tilt forward / backward (degrees)	FHB30-F2		FHB30L-F2	
		Lowered	Extended			Load Capacity (kgs) @ load centre (mm)		Load Capacity (kgs) @ load centre (mm)	
						500	600	500	600
2 STAGE	3030	2045*	4085	100	6 - 8	3000	2700	3000	2700
	3270	2165*	4325	100	6 - 8	3000	2700	3000	2700
	3700	2430	4755	100	6 - 8	3000	2700	3000	2700
	4000	2610	5055	100	6 - 8	3000	2700	3000	2700
	4500	2870	5555	100	6 - 8	3000	2700	3000	2700
	5000	3120	6055	100	6 - 8	2900	2700	3000	2700
	5500	3370	6555	100	6 - 4	2800	2600	2925	2700
	6000	3635	7055	100	6 - 4	2675	2475	2625	2575
2 STAGE FULL FREE LIFT	3000	2035*	4055	980	6 - 8	3000	2700	3000	2700
	3250	2165*	4305	1110	6 - 8	3000	2700	3000	2700
	3700	2430	4755	1375	6 - 8	3000	2700	3000	2700
3 STAGE FULL FREE LIFT	4010	2610	5065	1555	6 - 8	3000	2700	3000	2700
	3690	1825*	4745	770	6 - 6	3000	2700	3000	2700
	3990	1925*	5045	870	6 - 6	3000	2700	3000	2700
	4320	2045*	5375	990	6 - 6	3000	2700	3000	2700
	4700	2165*	5755	1110	6 - 6	2950	2700	3000	2700
	5060	2285	6115	1230	6 - 6	2875	2650	3000	2700
	5450	2430	6505	1375	6 - 6	2800	2600	2900	2700
	5970	2610	7025	1555	6 - 4	2625	2475	2725	2575
	6470	2870	7525	1815	6 - 4	1975	1975	2075	2075
	7000	3070	8055	2015	6 - 4	1425	1425	1575	1575

* Lower than overheadguard

** Without standard backrest: Extended height -350mm. Free lift height +350mm (full free lift masts only)

MAST SPECIFICATIONS & RATED CAPACITIES

MAST TYPE	Max fork height (mm)	Overall mast height (mm)		Free lift (mm)	Mast tilt forward / backward (degrees)	FHB35L-F2	
		Lowered	Extended			Load Capacity (kgs) @ load centre (mm)	
						500	600
2 STAGE	3000	2170*	4045	100	6 - 8	3500	3150
	3300	2290	4345	100	6 - 8	3500	3150
	3720	2500	4765	100	6 - 8	3500	3150
	4000	2755	5045	100	6 - 8	3500	3150
	4500	3000	5545	100	6 - 8	3500	3150
	5000	3250	6045	100	6 - 8	3500	3150
	5500	3500	6545	100	6 - 4	3400	3150
	6000	3750	7045	100	6 - 4	2775	2775
	3010	2170*	4055	1125	6 - 8	3500	3150
	3300	2290	4345	1245	6 - 8	3500	3150
2 STAGE FULL FREE LIFT	3720	2615	4765	1570	6 - 8	3500	3150
	4000	2755	5045	1710	6 - 8	3500	3150
	4000	2755	5045	1710	6 - 8	3500	3150
3 STAGE FULL FREE LIFT	3730	1930*	4775	885	6 - 6	3500	3150
	4010	2050*	5055	1005	6 - 6	3500	3150
	4390	2170*	5435	1125	6 - 6	3500	3150
	4700	2290	5745	1245	6 - 6	3500	3150
	5030	2435	6075	1390	6 - 6	3450	3150
	5580	2615	6625	1570	6 - 6	3175	3075
	6000	2755	7045	1710	6 - 4	2	

FHB25-35(L)-F2

STANDARD AND OPTIONS LIST

	ALL MODELS
GENERAL	
4-wheel chassis, 80 volts, front wheel dual drive	●
Forks with a length of 1,070mm, equipped with load backrest	●
3-valve hydraulic fingertip control mounted on an ergonomic armrest	●
Key pre-set economy or high performance mode (ECO / PRO)	●
Battery compartment side door	●
Multifunctional interactive full colour display	●
Intelligent curve control	●
Tiltable steering column	●
TruckTool setup and diagnostics	●
PDS (Seat Switch Timeout = all functions are disabled, the truck will go into the stop mode, automatically applied parking brake)	●
Full-suspension vinyl Grammer MSG65 seat	●
CE name plates -language markings	●
Operations and Maintenance Manual	●
DIN battery connectors on frame	●
Battery door detection sensor	●
Fingertip control armrest	●
Manual control levers	●
Dual Joystick	●
POWER SOURCE	
Integrated Li-ion battery*	●
Lead acid battery	●
FRAME	
Battery sideway exchange chassis	●
Roller bed, chassis integrated (for battery SWE)	●
Battery tray (for roller guided battery SWE)	●
Battery sideway exchange tool	●
Li-ion battery easy charging	●
T-bar battery stand	●
LIGHTING	
LED work lights (2 at the front and 1 at the rear)	●
Automated reversing light	●
Auto light switch	●
Amber strobe	●
Amber strobe mounted low	●
"Blue point" rear light	●
"Blue point" rear light mounted low	●
ELECTRICAL SYSTEM	
Smart backup alarm	●
Current output	●
12V connector	●
Operator presence pedal	●
Electronic differential lock	●
Dual pedal layout	●
Drive direction selection switch on ergonomic armrest (Forward-Backward) *Only on FC controls	●
Drive direction lever in steering column (Forward-Neutral-Reverse)	●
Road light kit	●
PIN code access with start switch	●
Automated lift controls	●
Automatic tilt centering via the F2 button with FC TILT/C	●
Load weight indicator	●
OPERATOR'S CABIN	
Grammer MSG65 seat	●
Grammer MSG65 with heater	●
Grammer MSG65 with cloth upholstery	●
Grammer MSG65 with cloth upholstery and heater	●
Grammer MSG75	●
Grammer MSG75 with heater	●
Grammer MSG75 with cloth upholstery	●
Grammer MSG75 with cloth upholstery and heater	●
Backrest extension	●

	ALL MODELS
ACCESSORIES	
Rear view mirror	●
External rear view mirror	●
Dead angle mirror	●
Wide view mirror	●
A4 size paper holder	●
Accessory clamp	●
Fire extinguisher	●
CABIN	
Steel doors, available in combination with options REAR and FR+TP	●
PVC doors, available in combination with options REAR and FR+TP	●
Sun visor, available in combination with option FR+TP	●
Interior package, available in combination with REAR and door	●
Heater, available in combination with REAR and steel doors, 2000 W	●
Safety doors	●
Container design. This option is available only with sideway battery exchange option SWE.	●
Delux cabin	●
EXTERIOR	
Special colour (RAL) for the frame and counterweight	●
FORKS & CARRIAGE	
Various fork lengths (920 - 1970mm), widths (100/120mm) and thicknesses (40/45mm), fork deletion	●
Side shifter W1000mm	●
Integrated side shifter W1000mm	●
Fork positioner+ integrated side shifter	●
Load backrest	●
HYDRAULIC SYSTEM	
3/4/5-way valve armrest-mounted fingertip control	●
3/4-way valve manual control	●
Lift Control	●
Double action FC 3 v, for clamp usage	●
Double action FC 4 v, for clamp usage	●
Double action MC 3 v, for clamp usage	●
Double action MC 4 v, for clamp usage	●
Hydraulic accumulator	●
Adjustable hydraulic pressure (for 3rd and 4th valve)	●
Food grade hydraulic oil	●
Biodegradable hydraulic oil	●
Cold area hydraulic oil VG15	●
Hot area hydraulic oil VG46	●
3-way piping	●
4-way piping	●
TYRES	
Solid Pneumatic Tyres	●
Pneumatic Tyres	●
Non-marking Solid Tyres	●
Non-marking Cushion tyres	●
Cushion tyres	●
Solid Pneumatic Twin Tyres	●
Wide Stance drive wheels	●

*Li-ion battery option is available in selected regions

KEY ● Standard ● Option



TCM
Always Evolving

info@tcm.eu | tcm.eu

Mitsubishi Logisnext Europe BV reserves the right to make any changes without notice concerning colours, equipment or specifications detailed in this brochure, or to discontinue individual models. The colours of vehicles delivered may differ slightly from those in this brochure. The specifications vary for different countries depending on local market conditions. Please consult your local dealer to ensure that the vehicle delivered accords with your expectations. All values are determined based on the standard condition and may vary, due to motor and system tolerances, condition of the truck and operational conditions. Some equipment shown on photos are optional. CESC2152-0523