

TECHNICAL SPECIFICATIONS

FD/ FGE40-55(C)-E2



STANDARD SPECIFICATIONS

		Counterbalance trucks Designation according VDI 3586	Data sheet for materials handling equipment					VDI 2198
		Manufacturers Data and Design Characteristics						
CHARACTERISTICS	1.1	Manufacturer	TCM Forklifts					
	1.2	Model name	FD40-E2 Diesel	FD45-E2 Diesel	FD50C-E2 Diesel	FD50-E2 Diesel	FD55-E2 Diesel	
		Manufacturer's type designation	E2F4F40/F	E2F4F45/F	E2F4F50C/F	E2F4F50/F	E2F4F55/F	
	1.3	Power source: Battery, Diesel, LPG, Petrol	Diesel					
	1.4	Operator type: pedestrian, (operator)-standing, -seated	Seated	Seated	Seated	Seated	Seated	
	1.5	Load capacity	Q (kg)	4000	4500	5000	5000	5500
	1.6	Load centre	c (mm)	500	500	500	600	600
	1.8	Front overhang	x (mm)	577	577	582	602	602
	1.9	Wheel base	y (mm)	1850	2000	2000	2150	2150
WEIGHTS	2.1	Truck weight, without load/including battery	kg	5920	6330	6850	7300	7640
	2.2	Axle loading with maximum load, front/rear	kg	8960/960	9710/1130	10600/1250	11020/1280	11740/1400
	2.3	Axle load without load, front/rear	kg	2630/3290	2780/3550	2900/3950	3220/4080	3170/4470
WHEELS, DRIVE TRAIN	3.1	Tyres: V=solid, L=pneumatic, SE=solid pneumatic - front/rear	L/L	L/L	L/L	L/L	SE/SE	
	3.2	Tyre dimensions, front	8.25-15-14PR	300-15-18PR	300-15-18PR	300-15-18PR	300-15/8.00	
	3.3	Tyre dimensions, rear	7.00-12-14PR	7.00-12-14PR	7.00-12-14PR	7.00-12-14PR	7.00-12-14PR	
	3.5	Number of wheels, front/rear (x=driven)	2x/2	2x/2	2x/2	2x/2	2x/2	
	3.6	Track width (centre of tyres), front	b10 (mm)	1175	1175	1175	1175	1175
	3.7	Track width (centre of tyres), rear	b11 (mm)	1180	1180	1180	1180	1180
	DIMENSIONS	4.1	Mast tilt, forwards/backwards	α/β (°)	6/12	6/12	6/12	6/12
4.2		Height with mast lowered (see tables)	h_1 (mm)	2320	2320	2400	2400	2400
4.3		Free lift (see tables)	h_2 (mm)	150	150	150	160	160
4.4		Lift height (see tables)	h_3 (mm)	3300	3300	3300	3300	3300
4.5		Overall height with mast raised	h_4 (mm)	4430	4430	4580	4580	4580
4.7		Height to top of overhead guard	h_6 (mm)	2296	2296	2296	2296	2296
4.8		Seat height	h_7 (mm)	1082	1082	1082	1082	1082
4.12		Tow coupling height	h_{10} (mm)	395	395	395	395	395
4.19		Overall length	l_1 (mm)	4220	4350	4390	4530	4580
4.20		Length to fork face (includes fork thickness)	l_2 (mm)	3000	3130	3170	3310	3360
4.21		Overall width	b_1/b_2 (mm)	1415/1965	1460/1965	1460/1965	1460/1965	1460/1965
4.22		Fork dimensions (thickness, width, length)	s,e,l (mm)	50/150/1220	50/150/1220	50/150/1220	60/150/1220	60/150/1220
4.23		Fork carriage to DIN 15 173 A/B/no		3A	3A	3A	4A	4A
4.24		Fork carriage width	b_3 (mm)	1190	1190	1190	1190	1190
4.31		Ground clearance under mast, with load	m_1 (mm)	150	150	150	150	150
4.32		Ground clearance at centre of wheelbase, with load (forks lowered)	m_2 (mm)	227	227	227	227	227
4.33		Working aisle width with 1000 x 1200 mm pallets, crosswise	Ast (mm)	4357	4507	4542	4692	4742
4.34		Working aisle width with 800 x 1200 mm pallets, lengthwise	Ast (mm)	4557	4707	4742	4892	4942
4.35	Turning circle radius	Wa (mm)	2580	2730	2760	2890	2940	
4.36	Minimum distance between centres of rotation	b_{13} (mm)	836	903	903	971	971	
PERFORMANCE	5.1	Travel speed, with/without load	km/h	21.5/22.5	21.5/22.5	21/22	21/22	20.5/22
	5.2	Lifting speed, with/without load	mm/s	0.62/0.67	0.62/0.67	0.54/0.58	0.53/0.57	0.53/0.57
	5.3	Lowering speed, with/without load	mm/s	0.50/0.50	0.50/0.50	0.50/0.50	0.50/0.50	0.50/0.50
	5.5	Rated drawbar pull, with/without load (1.6km/h)	kN	25800/18200	25500/19300	24900/20000	24800/21900	24500/22100
	5.7	Gradeability, with/without load (1.6km/h)	%	27.3/26.7	24.6/26.5	21.8/25.4	21/26.4	19.3/25.3
	5.10	Service brakes (mechanical/hydraulic/electric/pneumatic)		Hydraulic				
IC ENGINE	7.1	Manufacturer/Type		D04EG-T	D04EG-T	D04EG-T	D04EG-T	D04EG-T
	7.2	Rated output to ISO 1585	kW	54	54	54	54	54
	7.3	Rated speed to DIN 70 020	rpm	2250	2250	2250	2250	2250
	7.4	Number of cylinders/cubic capacity	cm ³	4/3330	4/3330	4/3330	4/3330	4/3330
	7.6a	Max torque	Nm	260	260	260	260	260
	7.7a	Max torque at engine speed	rpm	1800	1800	1800	1800	1800
	MISCELLANEOUS	8.1	Type of drive control		Powershift 2/1	Powershift 2/1	Powershift 2/1	Powershift 2/1
10.1		Maximum operating pressure for attachments	bar	191	191	191	191	191
10.2		Oil flow for attachments	l/min	80	80	80	80	80
10.7		Noise level, value at operator's ear (EN 12053)	dB(A)	78.5	78.5	78.5	78.5	78.5
10.8		Towing coupling design/DIN type, ref.		PIN	PIN	PIN	PIN	PIN

STANDARD SPECIFICATIONS

		Counterbalance trucks Designation according VDI 3586	Data sheet for materials handling equipment				VDI 2198
		Manufacturers Data and Design Characteristics					
CHARACTERISTICS	1.1	Manufacturer	TCM Forklifts				
	1.2	Model name	FGE40-E2 LPG	FGE45-E2 LPG	FGE50C-E2 LPG	FGE50-E2 LPG	FGE55-E2 LPG
		Manufacturer's type designation	J2F4F40/F	J2F4F45/F	J2F4F50C/F	J2F4F50/F	J2F4F55/F
	1.3	Power source: Battery, Diesel, LPG, Petrol	LPG				
	1.4	Operator type: pedestrian, (operator)-standing, -seated	Seated	Seated	Seated	Seated	Seated
	1.5	Load capacity	Q (kg)	4000	4500	5000	5500
	1.6	Load centre	c (mm)	500	500	500	600
	1.8	Front overhang	x (mm)	577	577	582	602
	1.9	Wheel base	y (mm)	1850	2000	2000	2150
WEIGHTS	2.1	Truck weight, without load/including battery	kg	5860	6270	6780	7240
	2.2	Axle loading with maximum load, front/rear	kg	8940/920	9680/1090	10570/1210	10990/1250
	2.3	Axle load without load, front/rear	kg	2610/3250	2750/3520	2870/3920	3190/4050
WHEELS, DRIVE TRAIN	3.1	Tyres: V=solid, L=pneumatic, SE=solid pneumatic - front/rear	L/L	L/L	L/L	L/L	SE/SE
	3.2	Tyre dimensions, front	8.25-15-14PR	300-15-18PR	300-15-18PR	300-15-18PR	300-15/8.00
	3.3	Tyre dimensions, rear	7.00-12-14PR	7.00-12-14PR	7.00-12-14PR	7.00-12-14PR	7.00-12-14PR
	3.5	Number of wheels, front/rear (x=driven)	2x/2	2x/2	2x/2	2x/2	2x/2
	3.6	Track width (centre of tyres), front	b10 (mm)	1175	1175	1175	1175
	3.7	Track width (centre of tyres), rear	b11 (mm)	1180	1180	1180	1180
	DIMENSIONS	4.1	Mast tilt, forwards/backwards	α/β (°)	6/12	6/12	6/12
4.2		Height with mast lowered (see tables)	h_1 (mm)	2320	2320	2400	2400
4.3		Free lift (see tables)	h_2 (mm)	150	150	150	160
4.4		Lift height (see tables)	h_3 (mm)	3300	3300	3300	3300
4.5		Overall height with mast raised	h_4 (mm)	4430	4430	4580	4580
4.7		Height to top of overhead guard	h_6 (mm)	2296	2296	2296	2296
4.8		Seat height	h_7 (mm)	1082	1082	1082	1082
4.12		Tow coupling height	h_{10} (mm)	395	395	395	395
4.19		Overall length	l_1 (mm)	4220	4350	4390	4530
4.20		Length to fork face (includes fork thickness)	l_2 (mm)	3000	3130	3170	3310
4.21		Overall width	b_1/b_2 (mm)	1415/1965	1460/1965	1460/1965	1460/1965
4.22		Fork dimensions (thickness, width, length)	s,e,l (mm)	50/150/1220	50/150/1220	50/150/1220	60/150/1220
4.23		Fork carriage to DIN 15 173 A/B/no		3A	3A	3A	4A
4.24		Fork carriage width	b_3 (mm)	1190	1190	1190	1190
4.31		Ground clearance under mast, with load	m_1 (mm)	150	150	150	150
4.32		Ground clearance at centre of wheelbase, with load (forks lowered)	m_2 (mm)	227	227	227	227
4.33		Working aisle width with 1000 x 1200 mm pallets, crosswise	Ast (mm)	4357	4507	4542	4692
4.34	Working aisle width with 800 x 1200 mm pallets, lengthwise	Ast (mm)	4557	4707	4742	4892	
4.35	Turning circle radius	Wa (mm)	2580	2730	2760	2890	
4.36	Minimum distance between centres of rotation	b_{13} (mm)	836	903	903	971	
PERFORMANCE	5.1	Travel speed, with/without load	km/h	23/23.5	22.5/23.5	22.5/23.5	22/23
	5.2	Lifting speed, with/without load	mm/s	0.67/0.69	0.67/0.69	0.58/0.59	0.57/0.59
	5.3	Lowering speed, with/without load	mm/s	0.50/0.50	0.50/0.50	0.50/0.50	0.50/0.50
	5.5	Rated drawbar pull, with/without load (1.6km/h)	kN	28700/17800	28400/19000	27800/19700	27700/21600
	5.7	Gradeability, with/without load (1.6km/h)	%	30.8/26.3	27.7/26.3	24.6/25.2	23.7/26.2
	5.10	Service brakes (mechanical/hydraulic/electric/pneumatic)		Hydraulic			
IC ENGINE	7.1	Manufacturer/Type	GK45	GK45	GK45	GK45	GK45
	7.2	Rated output to ISO 1585	kW	54	54	54	54
	7.3	Rated speed to DIN 70 020	rpm	2450	2450	2450	2450
	7.4	Number of cylinders/cubic capacity	cm ³	6/4450	6/4450	6/4450	6/4450
	7.6a	Max torque	Nm	283	283	283	283
	7.7a	Max torque at engine speed	rpm	1600	1600	1600	1600
	MISCELLANEOUS	8.1	Type of drive control	Powershift 2/1	Powershift 2/1	Powershift 2/1	Powershift 2/1
10.1		Maximum operating pressure for attachments	bar	191	191	191	191
10.2		Oil flow for attachments	l/min	80	80	80	80
10.7		Noise level, value at operator's ear (EN 12053)	dB(A)	75.4	75.4	75.4	75.4
10.8		Towing coupling design/DIN type, ref.		PIN	PIN	PIN	PIN

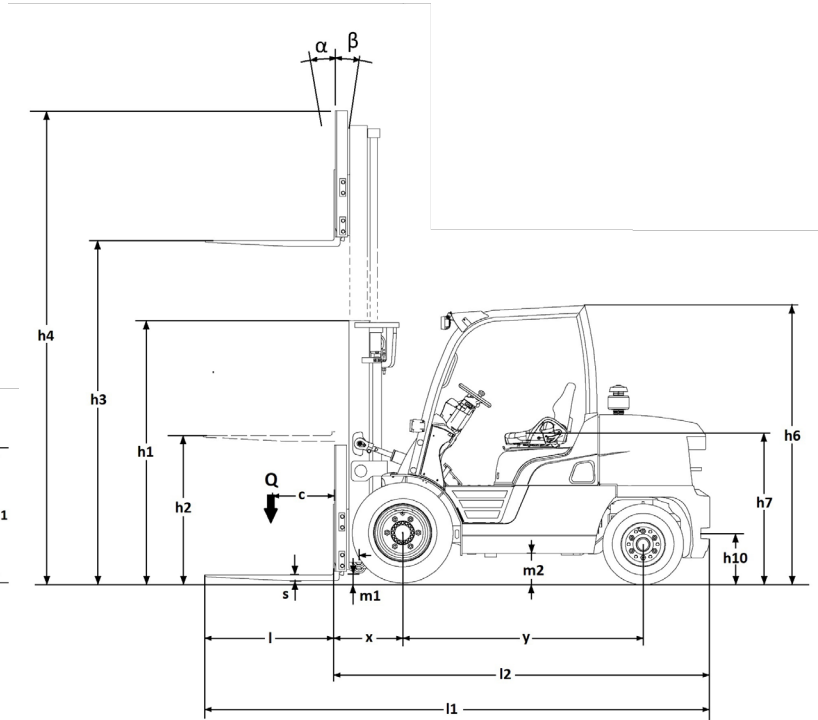
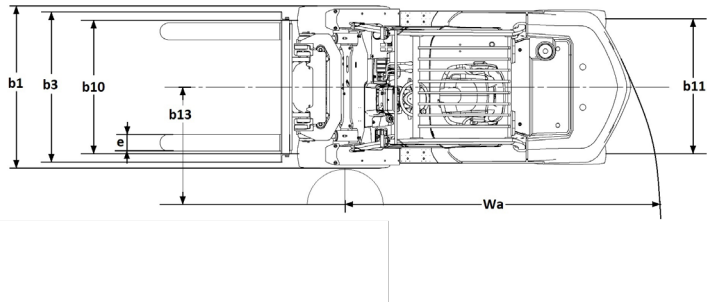

DIMENSIONS

MAST SPECIFICATIONS & RATED CAPACITIES: FD/FGE40-E2

Mast type	Mast name	Mast model	h3	h1	h4 mm		h2/h5 mm		Tilt angle Forward/backward	Q @ c = 500 mm	Q @ c = 600 mm
			mm	mm	With STD backrest	Without backrest	With STD backrest	Without backrest	degrees	kg	kg
SIMPLEX	2SP30	5V40C30	3050	2170	4130	3930	150	150	6°/12°	4000	3500
	2SP33	5V40C33	3350	2320	4430	4230	150	150	6°/12°	4000	3500
	2SP37	5V40C37	3750	2520	4830	4630	150	150	6°/12°	4000	3500
	2SP40	5V40C40	4050	2700	5130	4930	150	150	6°/12°	4000	3500
	2SP45	5V40C45	4550	3000	5630	5430	150	150	6°/6°	4000	3500
	2SP50	5V40C50	5050	3250	6130	5930	150	150	6°/6°	3850	3500
	2SP55	5V40C55	5550	3500	6630	6430	150	150	6°/6°	3650*	3400*
	2SP60	5V40C60	6050	3750	7130	6930	150	150	6°/6°	3500*	3300*
DUPLEX	2FP30	5F40C30	3050	2170	4130	3950	1090	1270	6°/12°	4000	3500
	2FP33	5F40C33	3350	2320	4430	4250	1240	1420	6°/12°	4000	3500
	2FP37	5F40C37	3750	2520	4830	4650	1440	1620	6°/12°	4000	3500
	2FP41	5F40C41	4110	2700	5190	5010	1620	1800	6°/12°	4000	3500
TRIPLEX	3FP40	5M40C40	4050	2050	5130	4950	970	1150	6°/6°	4000	3500
	3FP43	5M40C43	4410	2170	5490	5310	1090	1270	6°/6°	4000	3500
	3FP47	5M40C47	4750	2285	5830	5650	1200	1390	6°/6°	3900	3500
	3FP50	5M40C50	5100	2400	6180	6000	1320	1500	6°/6°	3800	3500
	3FP55	5M40C55	5550	2550	6630	6450	1470	1650	6°/6°	3600*	3400*
	3FP60	5M40C60	6050	2750	7130	6950	1670	1850	6°/6°	3450*	3250*
	3FP65	5M40C65	6550	2950	7630	7450	1870	2050	6°/6°	3000*	3000*
	3FP70	5M40C70	7050	3150	8130	7950	2070	2250	6°/6°	2400*	2400*

*) Capacities shown require truck equipped with dual tyres. Consult your dealer for the maximum back tilt allowed, to obtain the capacities specified.

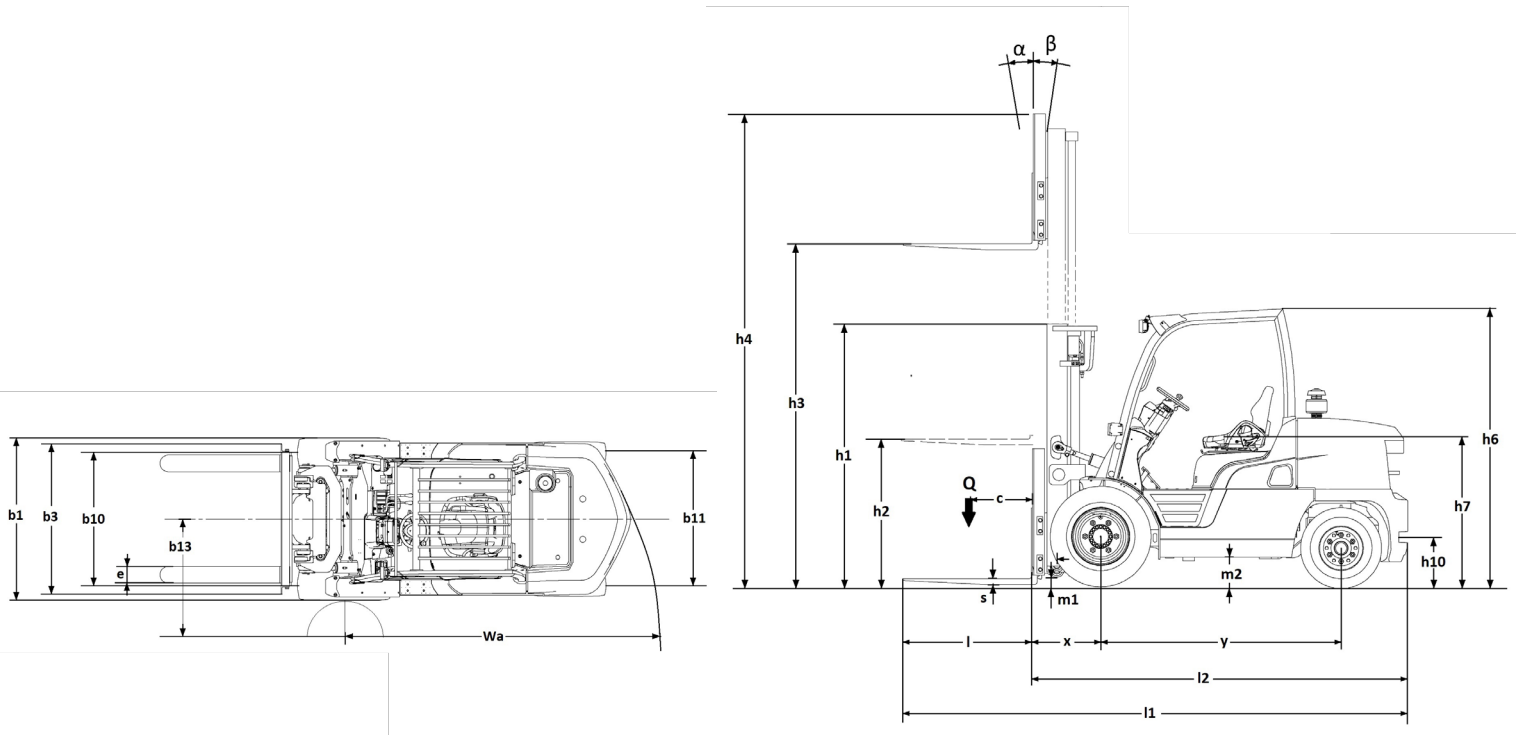

DIMENSIONS

MAST SPECIFICATIONS & RATED CAPACITIES: FD/FGE45-E2

Mast type	Mast name	Mast model	h3	h1	h4 mm		h2/h5 mm		Tilt angle Forward/backward	Q @ c = 500 mm	Q @ c = 600 mm
			mm	mm	With STD backrest	Without backrest	With STD backrest	Without backrest	degrees	kg	kg
SIMPLEX	2SP30	5V40C30	3050	2170	4130	3930	150	150	6°/12°	4500	4000
	2SP33	5V40C33	3350	2320	4430	4230	150	150	6°/12°	4500	4000
	2SP37	5V40C37	3750	2520	4830	4630	150	150	6°/12°	4500	4000
	2SP40	5V40C40	4050	2700	5130	4930	150	150	6°/12°	4500	4000
	2SP45	5V40C45	4550	3000	5630	5430	150	150	6°/6°	4500	4000
	2SP50	5V40C50	5050	3250	6130	5930	150	150	6°/6°	4500	4000
	2SP55	5V40C55	5550	3500	6630	6430	150	150	6°/6°	4300*	4000*
	2SP60	5V40C60	6050	3750	7130	6930	150	150	6°/6°	3900*	3900*
DUPLEX	2FP30	5F40C30	3050	2170	4130	3950	1090	1270	6°/12°	4500	4000
	2FP33	5F40C33	3350	2320	4430	4250	1240	1420	6°/12°	4500	4000
	2FP37	5F40C37	3750	2520	4830	4650	1440	1620	6°/12°	4500	4000
	2FP41	5F40C41	4110	2700	5190	5010	1620	1800	6°/12°	4500	4000
TRIPLEX	3FP40	5M40C40	4050	2050	5130	4950	970	1150	6°/6°	4500	4000
	3FP43	5M40C43	4410	2170	5490	5310	1090	1270	6°/6°	4500	4000
	3FP47	5M40C47	4750	2285	5830	5650	1200	1390	6°/6°	4500	4000
	3FP50	5M40C50	5100	2400	6180	6000	1320	1500	6°/6°	4500	4000
	3FP55	5M40C55	5550	2550	6630	6450	1470	1650	6°/6°	4200*	4000*
	3FP60	5M40C60	6050	2750	7130	6950	1670	1850	6°/6°	4050*	3800*
	3FP65	5M40C65	6550	2950	7630	7450	1870	2050	6°/6°	3000*	3000*
	3FP70	5M40C70	7050	3150	8130	7950	2070	2250	6°/6°	2400*	2400*

*) Capacities shown require truck equipped with dual tyres. Consult your dealer for the maximum back tilt allowed, to obtain the capacities specified.

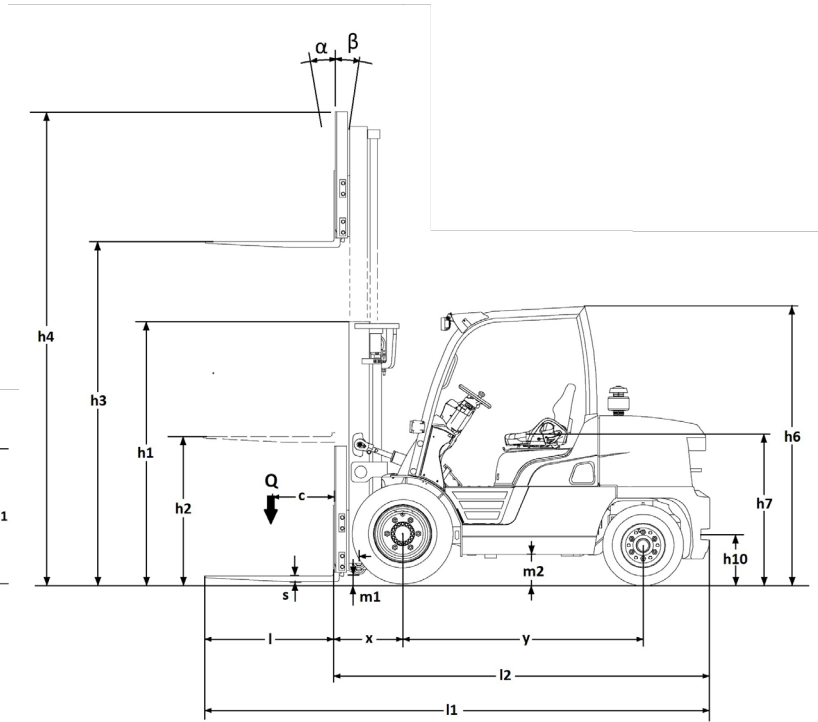
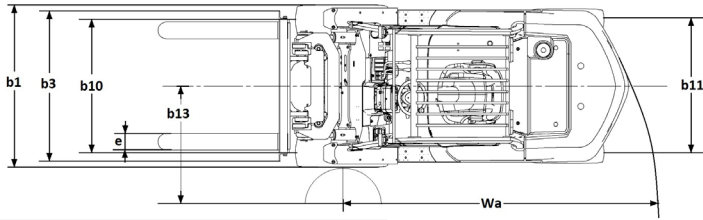

DIMENSIONS

MAST SPECIFICATIONS & RATED CAPACITIES: FD/FGE50C-E2

Mast type	Mast name	Mast model	h3 mm	h1 mm	h4 mm		h2/h5 mm		Tilt angle Forward/ backward degrees	Q @ c = 500 mm kg	Q @ c = 600 mm kg
					With STD backrest	Without backrest	With STD backrest	Without backrest			
SIMPLEX	2SP30	5V45C30	3050	2250	4130	3890	150	150	6°/12°	5000	4500
	2SP33	5V45C33	3350	2400	4430	4190	150	150	6°/12°	5000	4500
	2SP37	5V45C37	3750	2600	4830	4590	150	150	6°/12°	5000	4500
	2SP40	5V45C40	4050	2850	5130	4890	150	150	6°/12°	5000	4500
	2SP45	5V45C45	4550	3100	5630	5390	150	150	6°/6°	5000	4500
	2SP50	5V45C50	5050	3350	6130	5890	150	150	6°/6°	5000	4500
	2SP55	5V45C55	5550	3600	6630	6390	150	150	6°/6°	4750*	4500*
2SP60	5V45C60	6050	3850	7130	6890	150	150	6°/6°	3900*	3900*	
DU- PLEX	2FP30	5F45C30	3020	2250	4100	3870	1170	1400	6°/12°	5000	4500
	2FP33	5F45C33	3330	2400	4410	4180	1320	1550	6°/12°	5000	4500
	2FP41	5F45C41	4130	2850	5210	4980	1770	2000	6°/12°	5000	4500
TRIPLEX	3FP37	5M45C37	3750	2050	4830	4610	970	1200	6°/6°	5000	4500
	3FP40	5M45C40	4090	2170	5170	4950	1090	1320	6°/6°	5000	4500
	3FP43	5M45C43	4360	2260	5440	5220	1180	1410	6°/6°	5000	4500
	3FP47	5M45C47	4800	2400	5880	5660	1320	1550	6°/6°	5000	4500
	3FP50	5M45C50	5100	2500	6180	5960	1420	1650	6°/6°	5000	4500
	3FP55	5M45C55	5550	2650	6630	6410	1570	1800	6°/6°	4700*	4450*
	3FP60	5M45C60	6050	2850	7130	6910	1770	2000	6°/6°	4200*	4200*
	3FP65	5M45C65	6550	3050	7630	7410	1970	2200	6°/6°	3000*	3000*
	3FP70	5M45C70	7050	3250	8130	7910	2170	2400	6°/6°	2400*	2400*

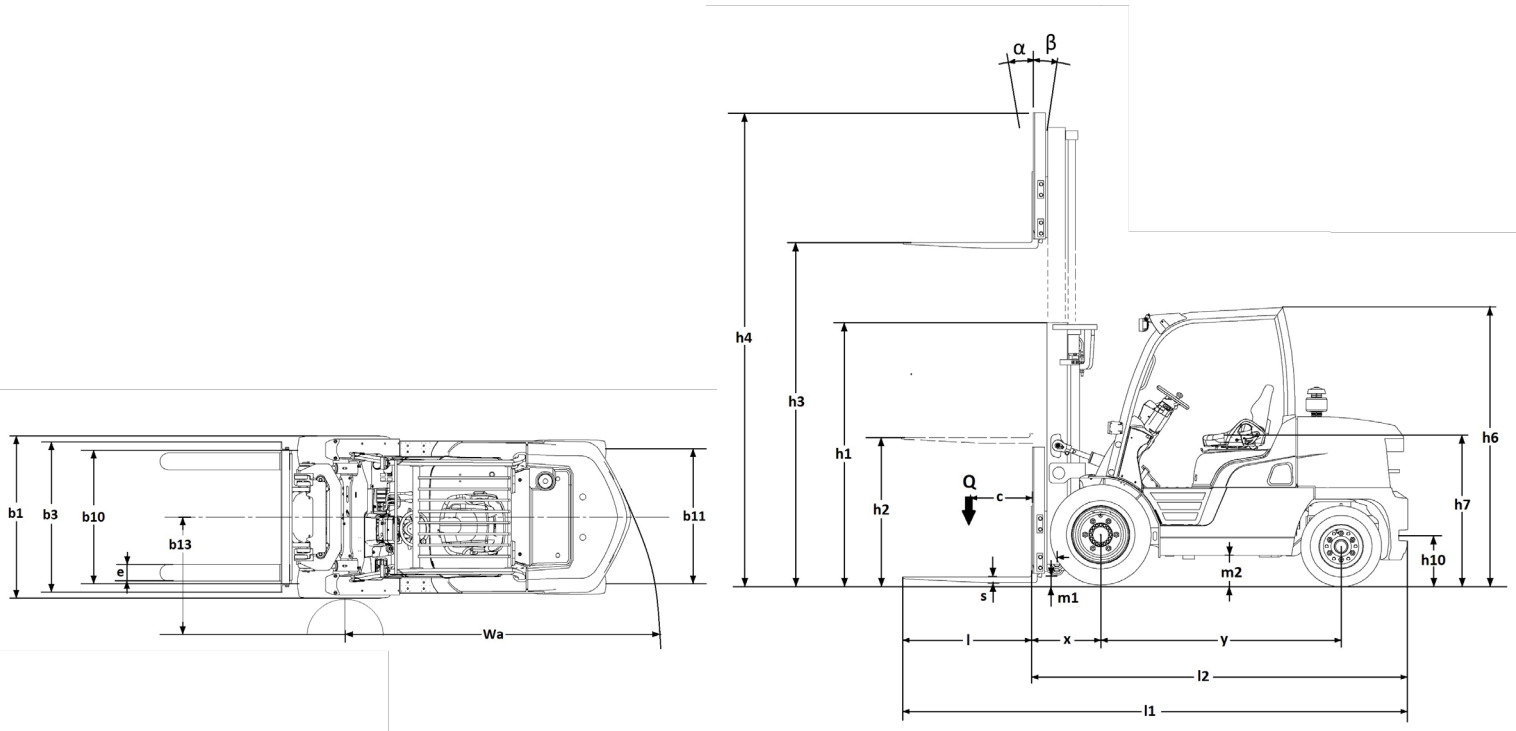

DIMENSIONS

MAST SPECIFICATIONS & RATED CAPACITIES: FD/FGE50-E2

Mast type	Mast name	Mast model	h3	h1	h4 mm		h2/h5 mm		Tilt angle Forward/backward	Q @ c = 600 mm
			mm	mm	With STD backrest	Without backrest	With STD backrest	Without backrest	degrees	kg
SIMPLEX	2SP30	5V50C30	3060	2250	4280	4030	160	160	6°/12°	5000
	2SP33	5V50C33	3360	2400	4580	4330	160	160	6°/12°	5000
	2SP37	5V50C37	3760	2600	4980	4730	160	160	6°/12°	5000
	2SP40	5V50C40	4060	2850	5280	5030	160	160	6°/12°	5000
	2SP45	5V50C45	4560	3100	5780	5530	160	160	6°/6°	5000
	2SP50	5V50C50	5060	3350	6280	6030	160	160	6°/6°	5000
	2SP55	5V50C55	5560	3600	6780	6530	160	160	6°/6°	4900*
	2SP60	5V50C60	6060	3850	7280	7030	160	160	6°/6°	4100*
DU- PLEX	2FP30	5F50C30	3030	2250	4250	4000	1025	1280	6°/12°	5000
	2FP33	5F50C33	3340	2400	4560	4310	1175	1430	6°/12°	5000
	2FP41	5F50C41	4140	2850	5360	5110	1625	1880	6°/12°	5000
TRIPLEX	3FP37	5M50C37	3760	2050	4980	4740	830	1080	6°/6°	5000
	3FP40	5M50C40	4100	2170	5320	5080	950	1200	6°/6°	5000
	3FP43	5M50C43	4370	2260	5590	5350	1040	1290	6°/6°	5000
	3FP47	5M50C47	4810	2400	6030	5790	1180	1430	6°/6°	5000
	3FP50	5M50C50	5110	2500	6330	6090	1280	1530	6°/6°	5000
	3FP55	5M50C55	5560	2650	6780	6540	1430	1680	6°/6°	4900*
	3FP60	5M50C60	6060	2850	7280	7040	1630	1880	6°/6°	4300*

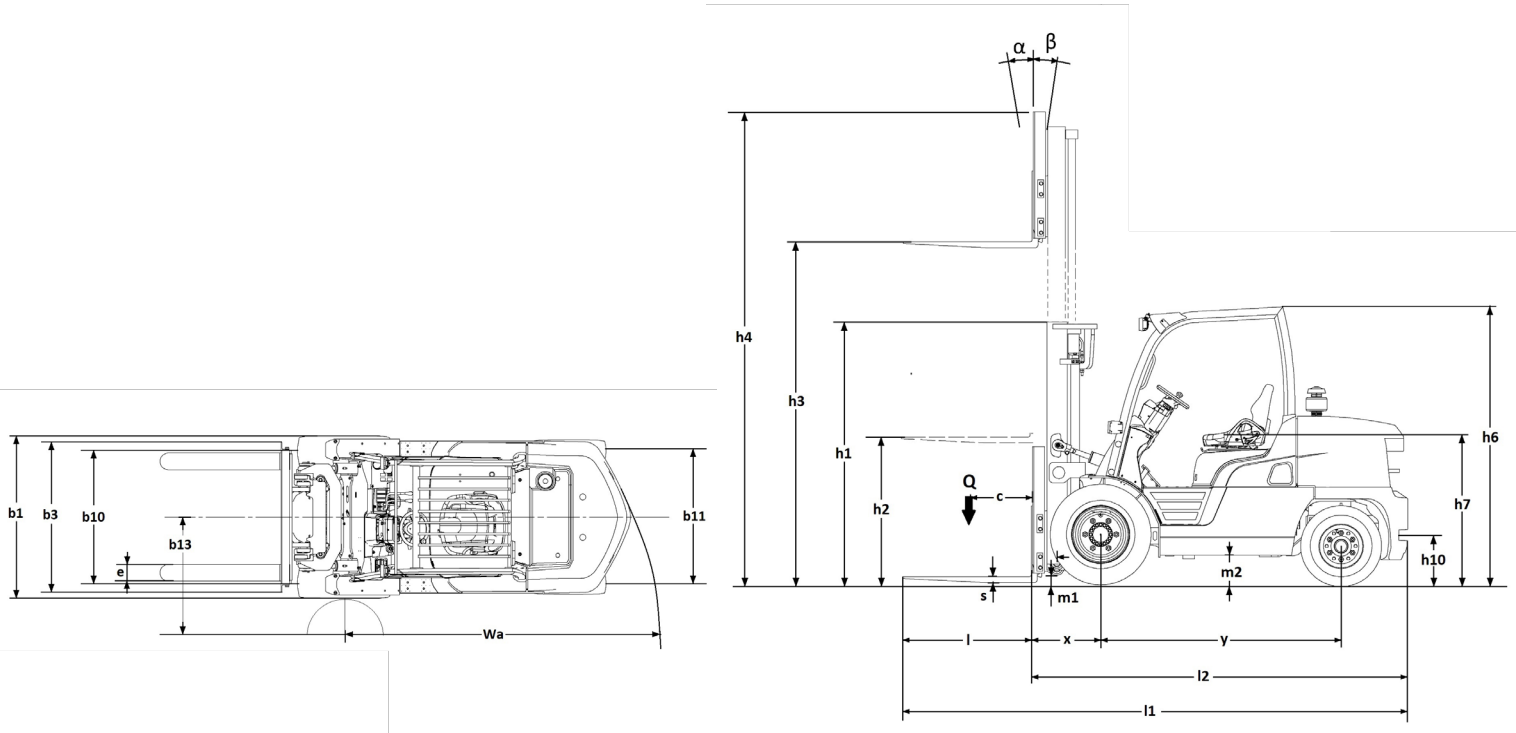

DIMENSIONS

MAST SPECIFICATIONS & RATED CAPACITIES: FD/FGE55-E2

Mast type	Mast name	Mast model	h3	h1	h4 mm		h2/h5 mm		Tilt angle Forward/backward	Q @ c = 600 mm
			mm	mm	With STD backrest	Without backrest	With STD backrest	Without backrest	degrees	kg
SIMPLEX	2SP30	5V55C30	3060	2250	4280	4030	160	160	6°/12°	5500
	2SP33	5V55C33	3360	2400	4580	4330	160	160	6°/12°	5500
	2SP37	5V55C37	3760	2600	4980	4730	160	160	6°/12°	5500
	2SP40	5V55C40	4060	2850	5280	5030	160	160	6°/12°	5500
	2SP45	5V55C45	4560	3100	5780	5530	160	160	6°/6°	5500
	2SP50	5V55C50	5060	3350	6280	6030	160	160	6°/6°	5500
	2SP55	5V55C55	5560	3600	6780	6530	160	160	6°/6°	5500
	2SP60	5V55C60	6060	3850	7280	7030	160	160	6°/6°	5350*
DU-PLEX	2FP30	5F50C30	3030	2250	4250	4000	1025	1280	6°/12°	5500
	2FP33	5F50C33	3340	2400	4560	4310	1175	1430	6°/12°	5500
	2FP41	5F50C41	4140	2850	5360	5110	1625	1880	6°/12°	5500
TRIPLEX	3FP37	5M50C37	3760	2050	4980	4740	830	1080	6°/6°	5500
	3FP40	5M50C40	4100	2170	5320	5080	950	1200	6°/6°	5500
	3FP43	5M50C43	4370	2260	5590	5350	1040	1290	6°/6°	5500
	3FP47	5M50C47	4810	2400	6030	5790	1180	1430	6°/6°	5500
	3FP50	5M50C50	5110	2500	6330	6090	1280	1530	6°/6°	5500
	3FP55	5M50C55	5560	2650	6780	6540	1430	1680	6°/6°	5500
	3FP60	5M50C60	6060	2850	7280	7040	1630	1880	6°/6°	5300*

*) Capacities shown require truck equipped with dual tyres. Consult your dealer for the maximum back tilt allowed, to obtain the capacities specified.

FD/ FGE40-55(C)-E2



info@tcm.eu | tcm.eu

TCM
Always Evolving

© 2021 MLE B.V. (registration no. 33274459). All rights reserved.

MLE B.V. reserves the right to make any changes without notice concerning colours, equipment or specifications detailed in this brochure, or to discontinue individual models. The colours of vehicles delivered may differ slightly from those in this brochure. The specifications vary for different countries depending on local market conditions. Please consult your local dealer to ensure that the vehicle delivered accords with your expectations. All values are determined based on the standard condition and may vary, due to motor and system tolerances, condition of the truck and operational conditions. Some equipment shown on photos maybe optional.